

2位2通球阀



用法:

该阀用于高压油路的通断回路。

运用:

把油口A或P连接至需要断开的液压回路中。

当把手位置与阀体呈90°角时，油路断开；把手位置与阀体在同一直线时，油路联通。

机能符号

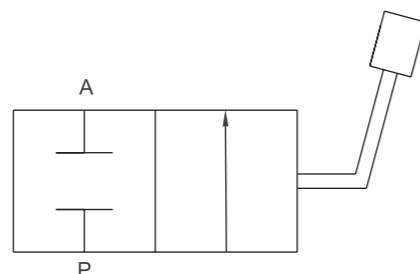

DIN/ISO 228 BSP 公制内螺纹

型号	MAX FLOW(L/min)	PN	DN	A/P	L	L1	L2	L3	L4	L5	D	H	H1	S
HYRS 2 VIE 1/4"	25	500	6	G1/4"	42	71	110	14	25	30	5.5	35	92	30
HYRS 2 VIE 3/8"	35	500	10	G3/8"	44	73	110	17	31	35	5.5	40	97	35
HYRS 2 VIE 1/2"	60	500	13	G1/2"	48	83	110	18	34	37	6.5	43	100	37
HYRS 2 VIE 3/4"	100	400	20	G3/4"	63	95	180	23	46	49	8.5	55	110	45
HYRS 2 VIE 1"	180	350	25	G1"	67	112	180	29	49	59	8.5	65	120	55
HYRS 2 VIE 1 1/4"	180	350	25	G1 1/4"	67	120	180	29	49	59	8.5	65	120	55
HYRS 2 VIE 1 1/2"	180	350	25	G1 1/2"	67	124	180	29	49	59	8.5	65	120	55

2位2通球阀

外形尺寸

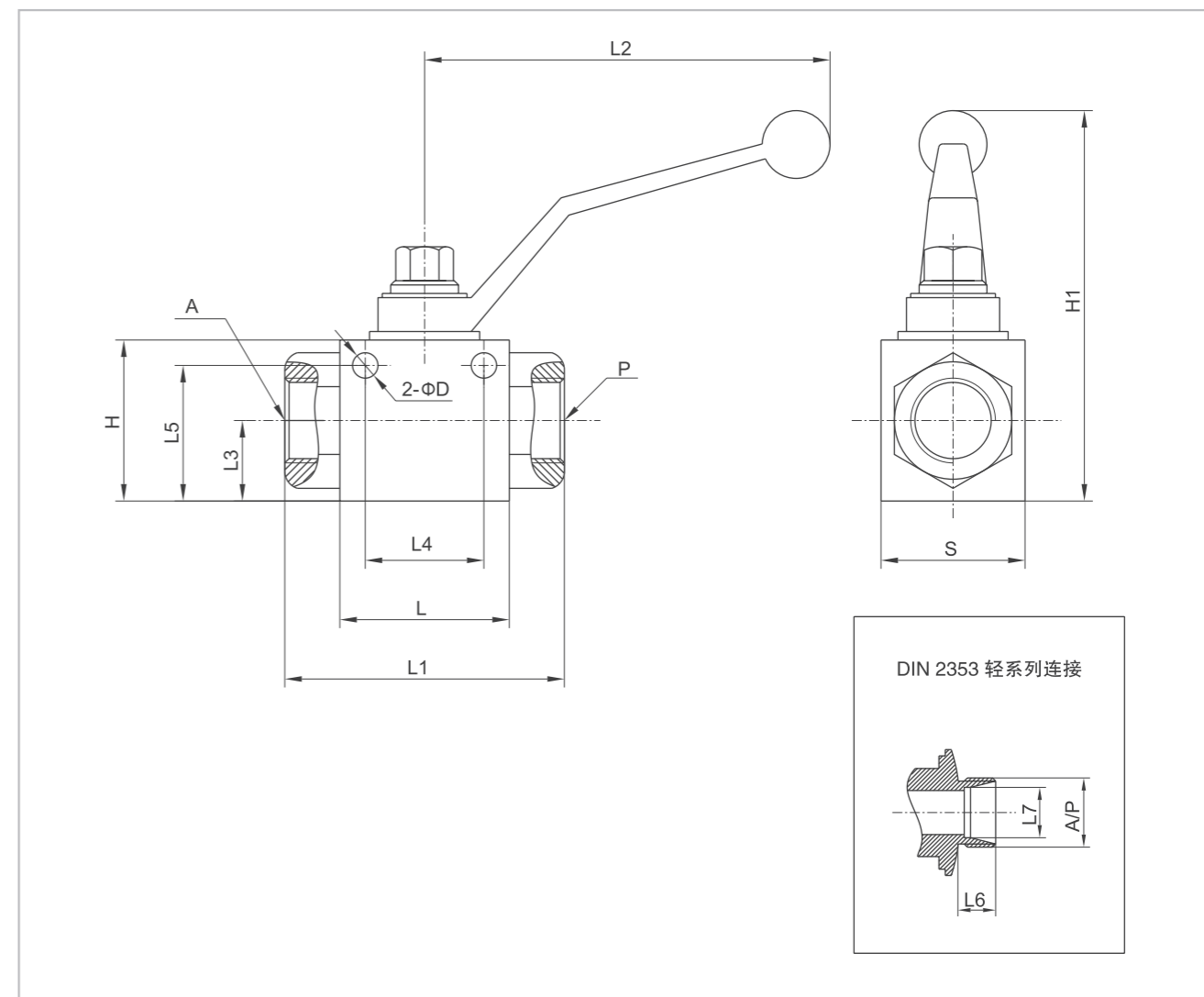

DIN 2353 轻系列公制螺纹

型号	MAX FLOW(L/min)	PN	DN	A/P	L	L1	L2	L3	L4	L5	L6	L7	D	H	H1	S
HYRS 2 VIE M12x1.5	25	500	6	M12x1.5	42	76	110	14	25	30	10	6	5.5	35	92	30
HYRS 2 VIE M14x1.5	25	500	6	M14x1.5	42	76	110	14	25	30	10	8	5.5	35	92	30
HYRS 2 VIE M16x1.5	25	500	6	M16x1.5	42	76	110	14	25	30	11	10	5.5	35	92	30
HYRS 2 VIE M16x1.5	35	500	10	M16x1.5	44	76	110	17	31	35	11	10	5.5	40	97	35
HYRS 2 VIE M18x1.5	35	500	10	M18x1.5	44	79	110	17	31	35	11	12	5.5	40	97	35
HYRS 2 VIE M22x1.5	60	500	13	M22x1.5	48	87	110	18	34	37	12	15	6.5	43	100	37
HYRS 2 VIE M26x1.5	60	500	13	M26x1.5	48	87	110	18	34	37	12	18	6.5	43	100	37
HYRS 2 VIE M30x2	100	400	20	M36x2	63	110	180	23	46	49	14	22	8.5	55	110	45
HYRS 2 VIE M36x2	180	350	25	M45x2	67	115	180	29	49	59	14	28	8.5	65	120	55
HYRS 2 VIE M45x2	180	350	25	M45x2	67	119	180	29	49	59	16	35	8.5	65	120	55
HYRS 2 VIE M52x2	180	350	25	M52x2	67	120	180	29	49	59	16	42	8.5	65	120	55